

# TC-EDGE

CONTROLLO DIFETTI SQUADRATURA  
SQUARING DEFECT CONTROL



CONTROLLO FASE 1  
CONTROL PHASE 1



CONTROLLO FASE 2  
CONTROL PHASE 2



CONTROLLO FASE 3  
CONTROL PHASE 3

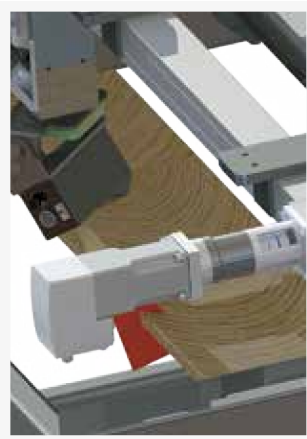

## Difetti rilevati da TC-EDGE Defects detected by TC-EDGE



Angolo Bisello - Chamfer Corner





Angolo Bordo - Corner Side



Misura Bisello - Chamfer Measurement



Difetto sbecatura - Breaking Control

Alimentazione - Power supply	380 VAC 1 W
Cpu	PLC standard
HMI pannello operatore - HMI operator pannel	10" touch screen
Condivisione dati - Data sharing	 
Cambio formato - Size change	Non necessario - No need
N° di sensori - N° of sensors	2
Risoluzione sensore - Sensor resolution	Z 0.012 - X 0.018
Distanza di lavoro - Working distance	90 mm
Ripetibilità - Repeatability	+/- 0.1 mm
Campo inquadrato - Field of view	50 - 80
Formato massimo - Maximum size	1800x∞ mm larghezza x lunghezza - width x lenght

