

Tile Control TC

CONTROLLO DIMENSIONALE, DIAGONALE E PLANARITÀ
DIMENSIONAL, DIAGONAL AND PLANARITY CONTROL

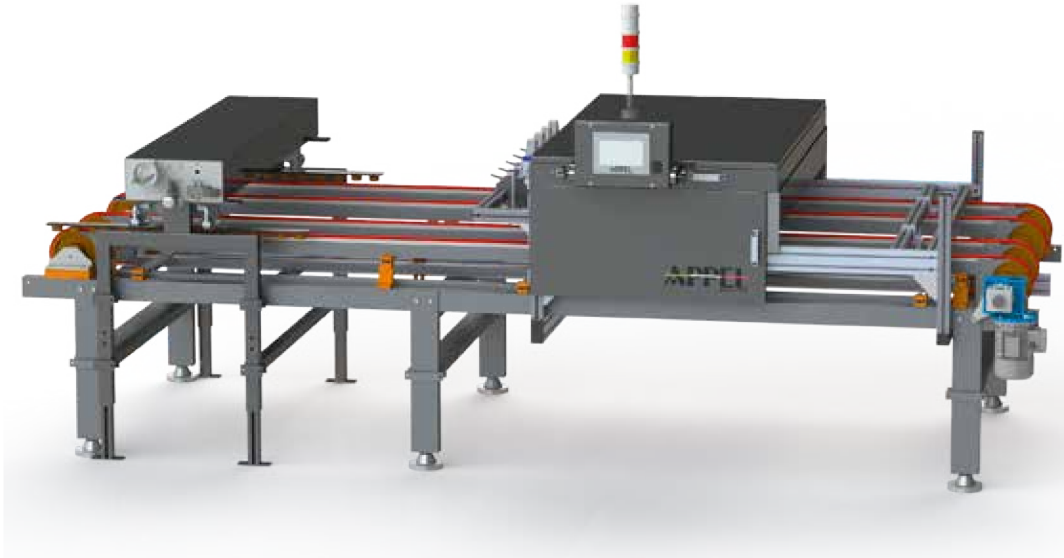

CONDIVISIONE DATI REMOTA
REMOTE DATA SHARING



HMI MENU PRINCIPALE
HMI MAIN MENU



PANNELLO OPERATORE
OPERATOR PANEL



SENSORI PLANER LASER
LASER PLANER SENSORS

Alimentazione - Power supply	85 ÷ 264 VAC 110 W
Cpu	PLC standard
Velocità max. linea Speed production	60 m/min 120 pz./min
HMI pannello operatore HMI interface	TFT 7" 65 K colours
Condivisione dati Data sharing	
Cambio formato Size change	Manuale Manual

PLANAR	
N. di sensori ottici - N. optical sensors	5
Tipo di sensori - Sensors type	LASER AP062 - STANDARD
Risoluzione - Resolution	0.05 mm
Ripetibilità - Repeatability	± 0.1 mm
Campo di misura - Measurement field	LASER = 70 mm
CALIBRO	
Tipo di sensori - Sensors type	LASER AP056-AP051 - STANDARD
Risoluzione - Resolution	0.02 mm
Ripetibilità - Repeatability	± 0.1 mm
Campo di misura - Measurement field	LASER=70 mm - AP051 = 28 mm

LAYOUT TC 600X600 MM

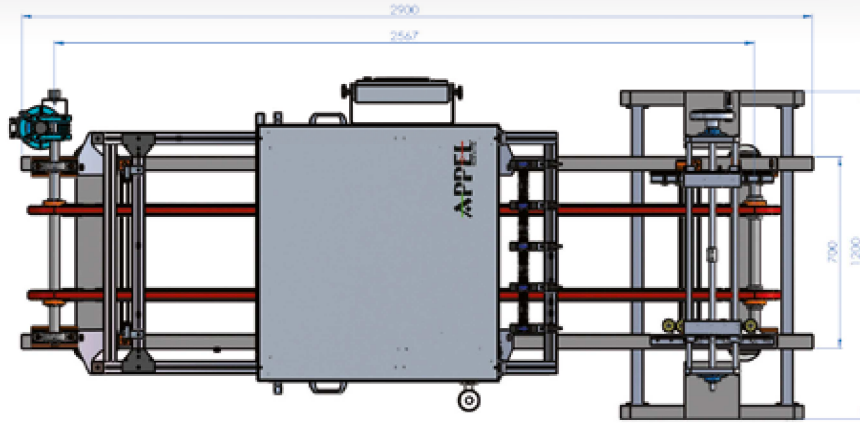

LAYOUT TC 1200X1200 MM

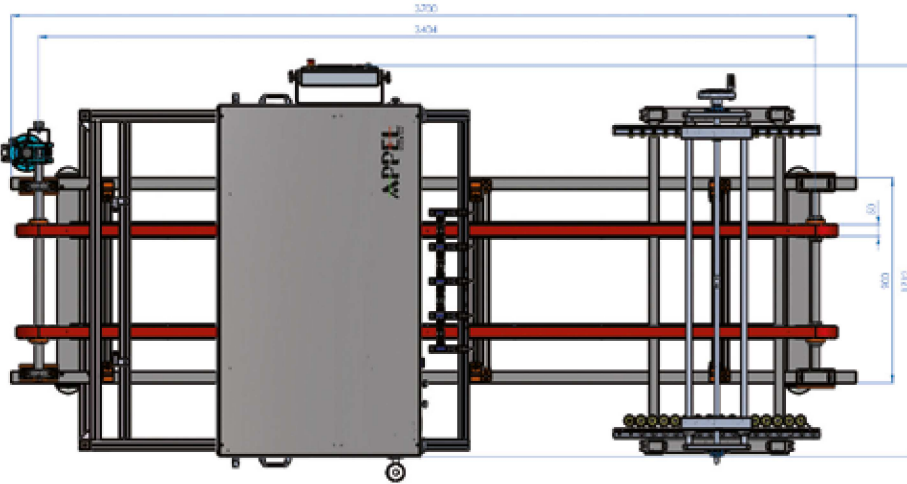

LAYOUT TC 1200X1600 MM

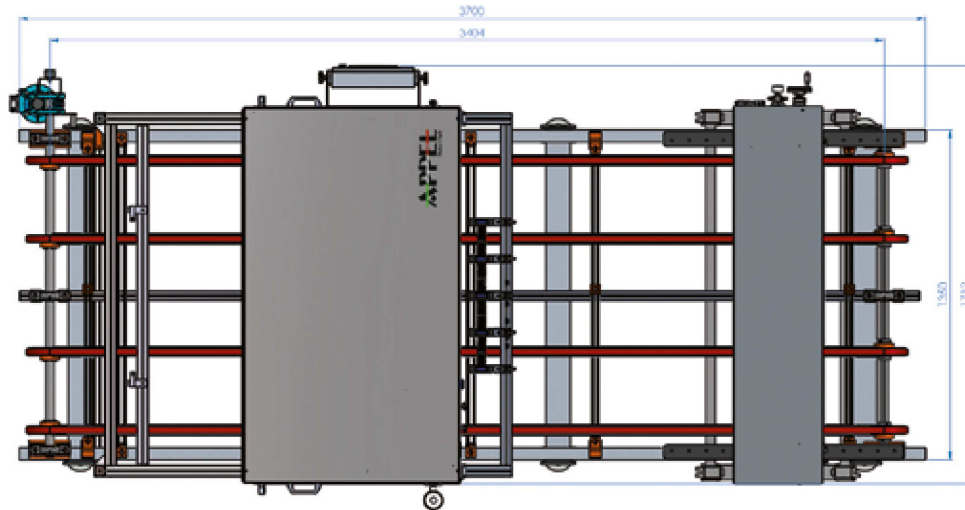

LAYOUT TC 1200X2500 MM

